

Automobility Vehicle Documentation Form AM-310-B
Vehicle Information Data:

Make CHEVROLET Model COBALT Year 2009

Hand Control Model # 21221

Notes:

- RIGHT OFFSET LOWER BRAKE ARM
- TILT STEERING IN FULL UPRIGHT POSITION
- CAMLOCKS ON TOP OF STEERING COLUMN AND AGAINST THE DASH.

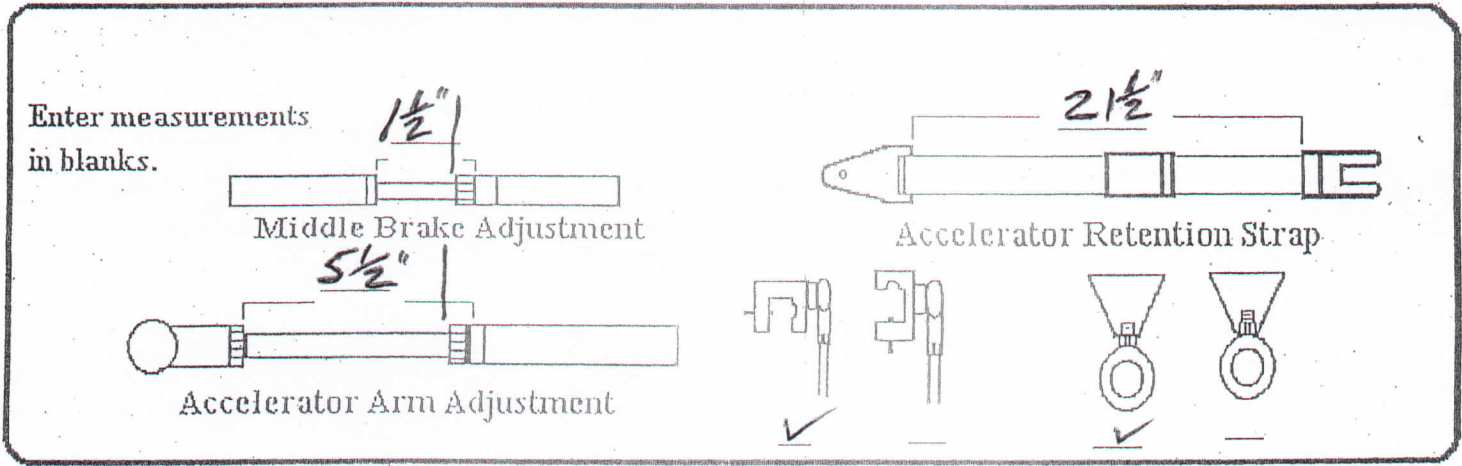
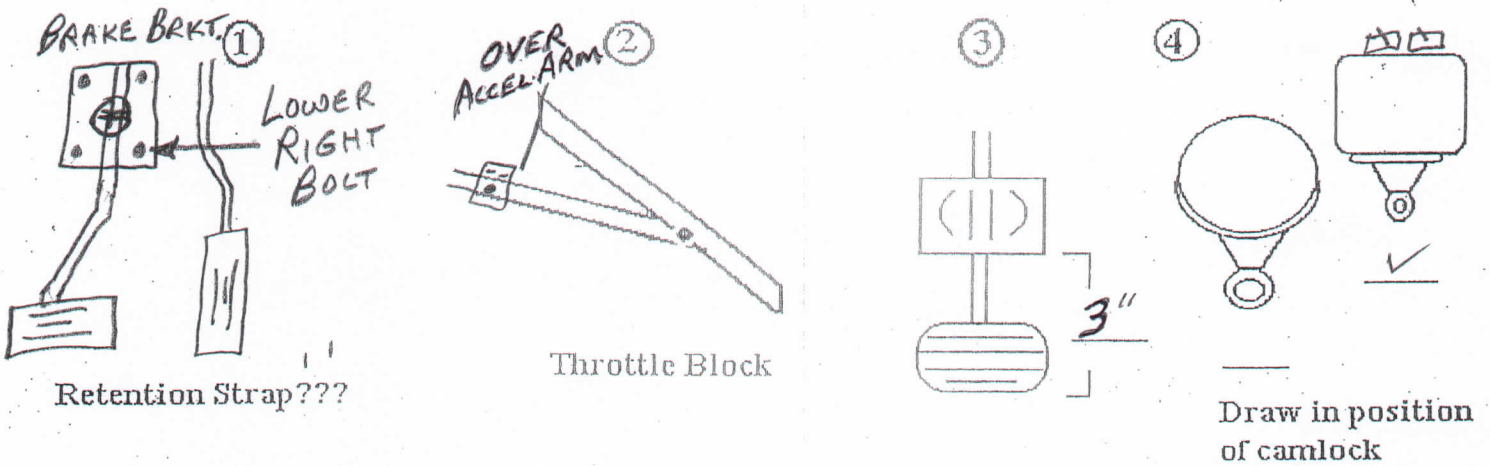

Automobility Vehicle Documentation Form AM-310-B
Vehicle Information Data:

Make CHEVROLET Model HHR Year 2009

Hand Control Model # 21221

Notes:

- RIGHT OFFSET LOWER BRAKE ARM
- TILT STEERING TO FULL UPRIGHT POSITION
- CAMLOCKS ON TOP OF STEERING COLUMN AND AGAINST THE DASH

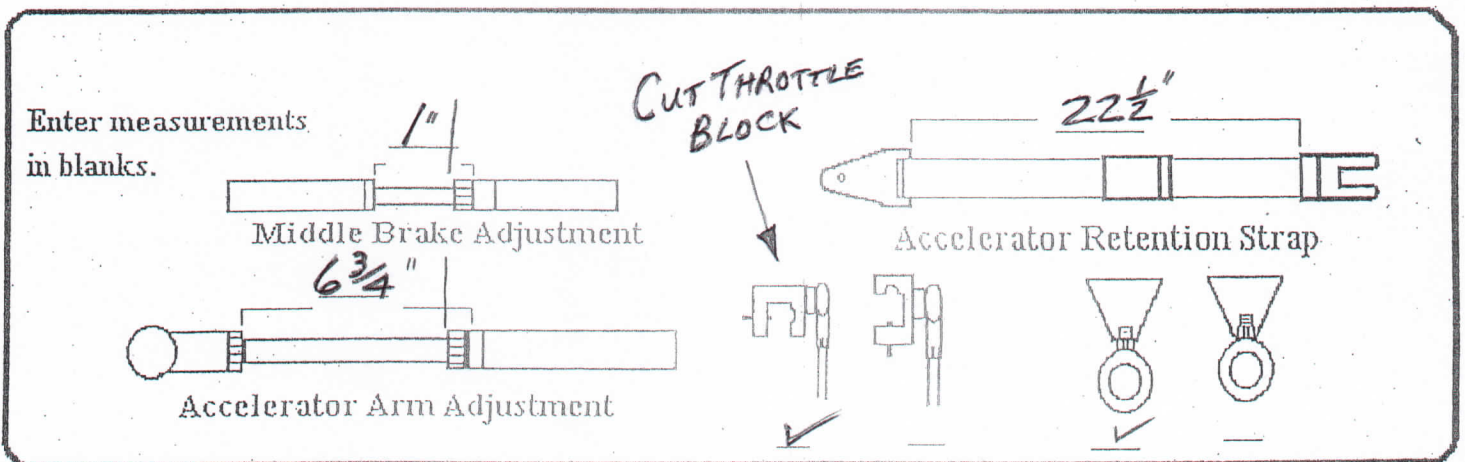
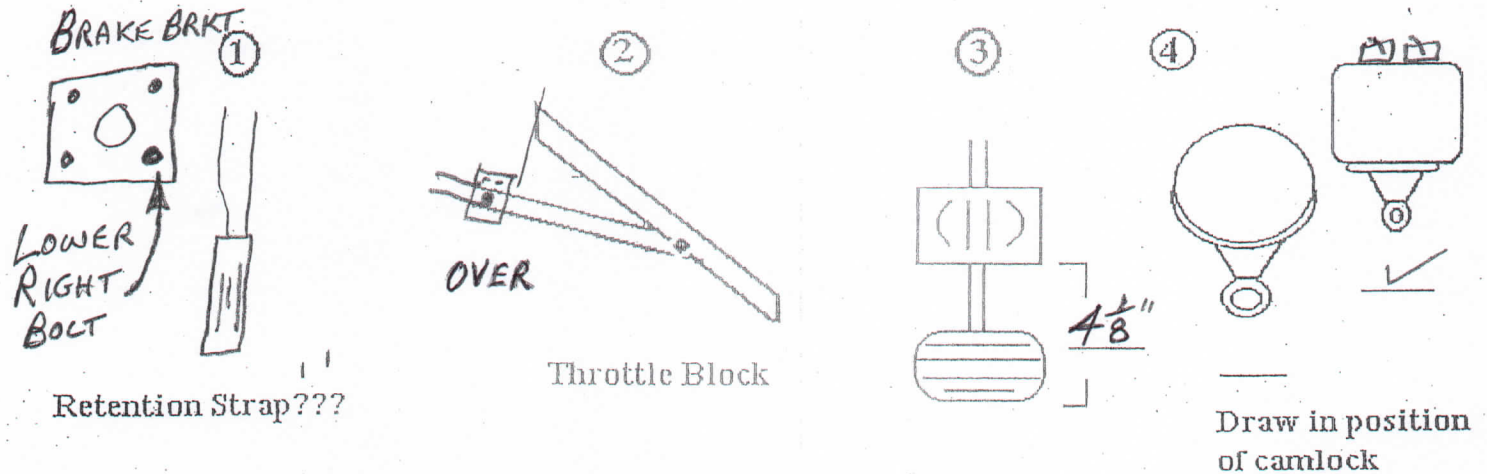

Automobility Vehicle Documentation Form AM-310-B
Vehicle Information Data:

Make CHEVROLET Model EQUINOX Year 2010

Hand Control Model # 21221

Notes: — RIGHT OFFSET LOWER BRAKE ARM

— TILT IN FULL UPRIGHT POSITION AND TELESCOPE OUT 1"

— TOWER STRAP GOES BEHIND TILT KNOB ON LEFT SIDE.

— CAMLOCKS ON TOP ON STEERING COLUMN AND AGAINST DASH.

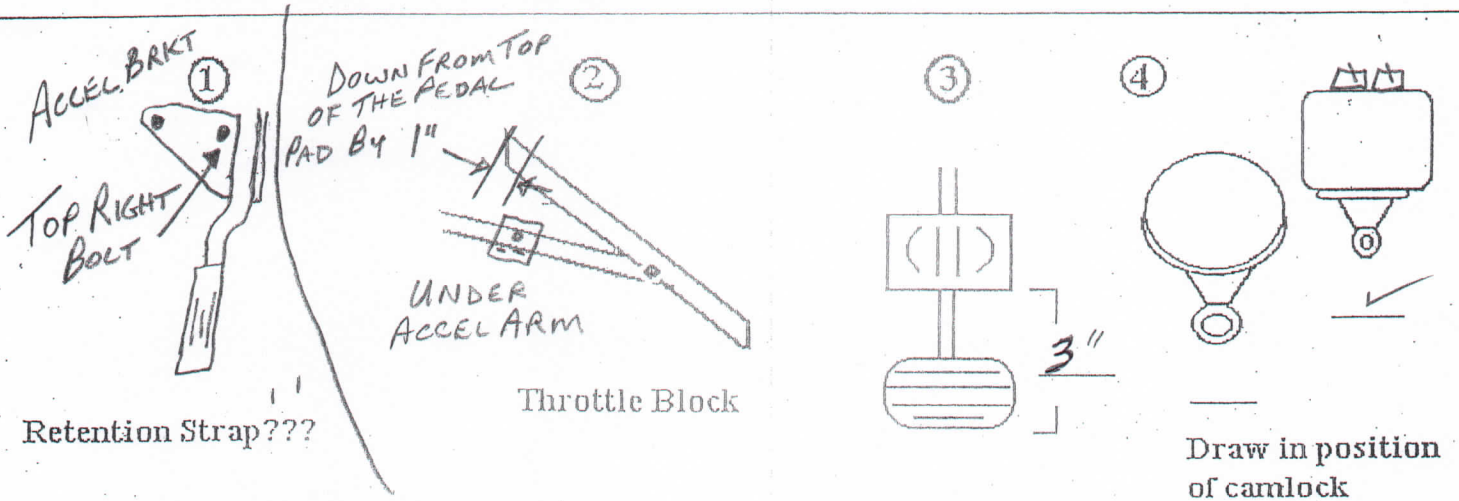

Enter measurements
in blanks.

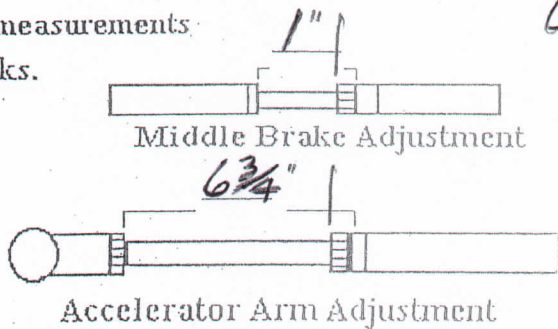

CUT THROTTLE
BLOCK

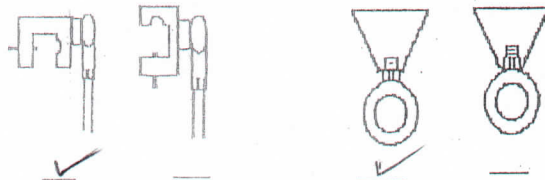
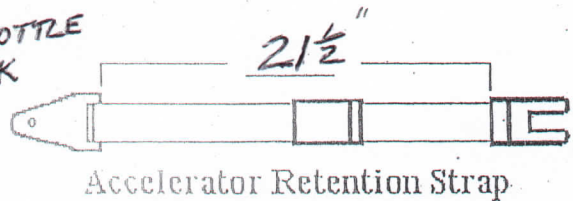

Automobility Vehicle Documentation Form AM-310-B
 Vehicle Information Data:

Make GMC/CHEV. Model ENVOY/TRAILBLAZER Year 2009

Hand. Control Model # 23221

Notes:

- STRAIGHT LOWER BRAKE ARM
- TILT IN FULL UPRIGHT POSITION
- CAMLOCKS ON TOP AGAINST DASH + ON RIGHT BELOW IGNITION SWITCH.
- TOWER STRAP GOES BEHIND TILT KNOB ON LEFT SIDE.

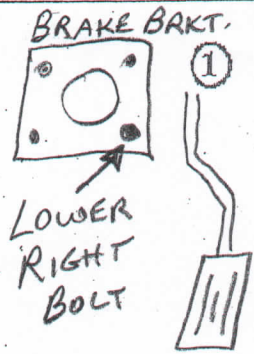

Retention Strap???

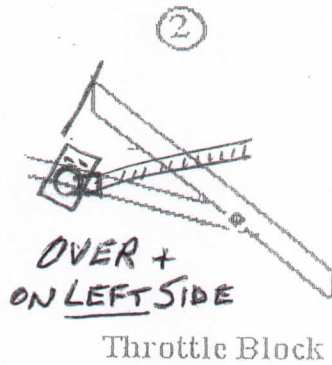

Throttle Block

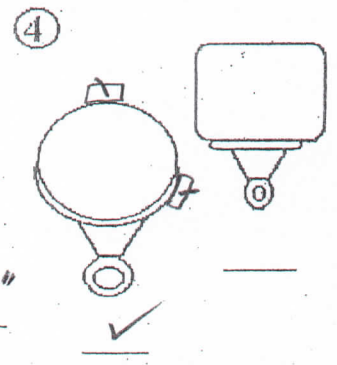
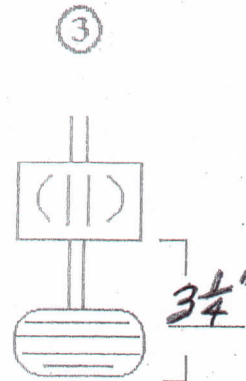

Draw in position of camlock

Enter measurements in blanks.

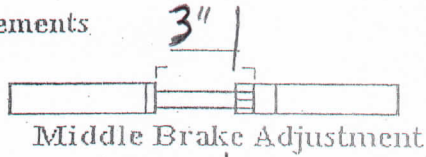

Middle Brake Adjustment

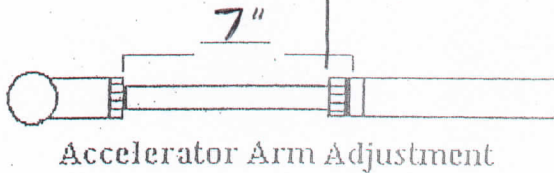

Accelerator Arm Adjustment

ROD END + LOWER ACCEL. ARM TO LEFT SIDE OF PEDAL

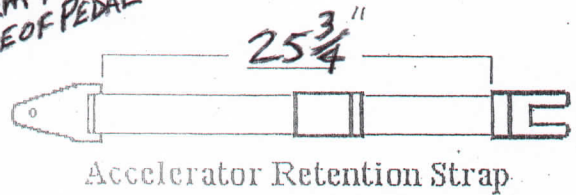

Accelerator Retention Strap

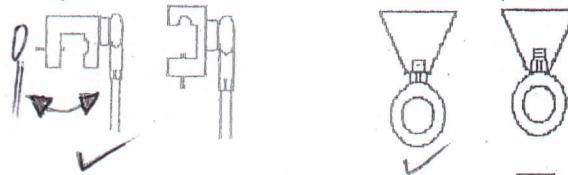

Automobility Vehicle Documentation Form AM-310-B
Vehicle Information Data:

Make PONTIAC Model VIBE Year 2009

Hand Control Model # 23321

(HARD)
INSTALLATION

Notes: - STRAIGHT LOWER BRAKE ARM

- 28° UPPER ACCELERATOR ARM

- CAMLOCKS ON LEFT + RIGHT SIDES ARE AGAINST THE DASH

- TILT STEERING IN UPRIGHT POSITION AND TELESCOPE OUT

- ROD END BEARING; CUT THREADS AND TURNED IN FULLY

- D-RING STRAP FROM TOWER GOES THROUGH AND BEHIND THE BOLSTER PAD

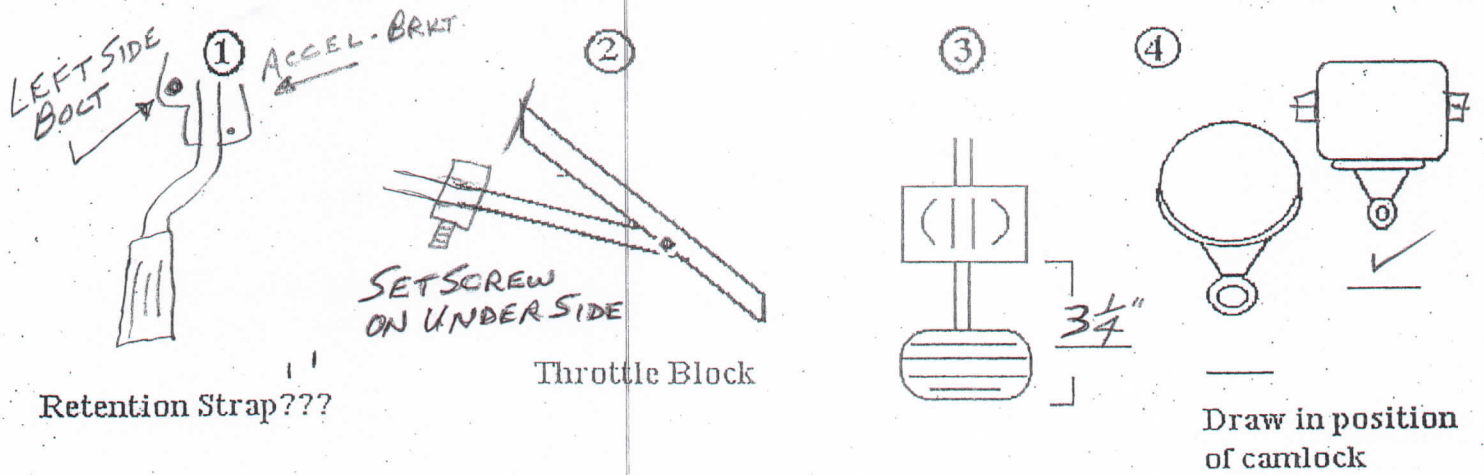

Enter measurements
in blanks.

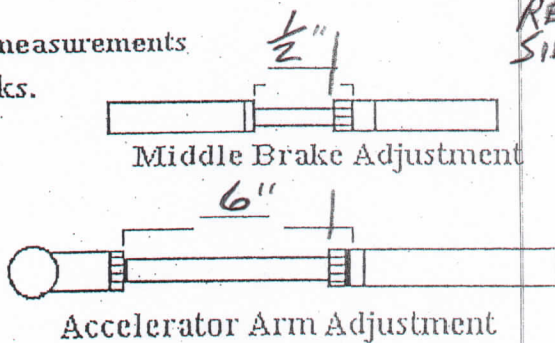

CUT THROTTLE BLOCK.
REVERSE TO LEFT
SIDE OF PEDAL

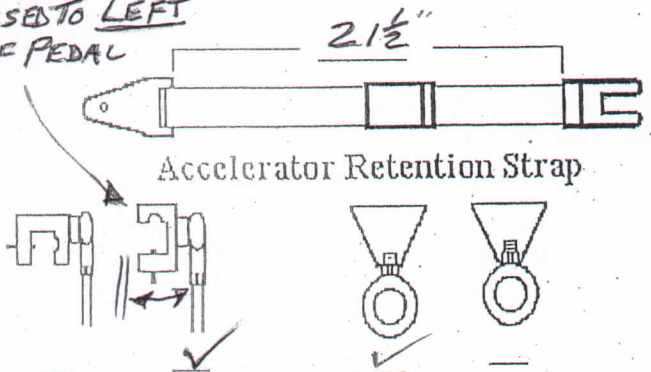

Automobility Vehicle Documentation Form AM-310-B
Vehicle Information Data:

Make PONTIAC Model G-6 Year 2009

Hand Control Model # 21221

Notes:

- RIGHT OFFSET LOWER BRAKE ARM
- TILT IN FULL UPRIGHT POSITION WITH TELESCOPE OUT $1\frac{1}{4}$ "
- CAMLOCKS AGAINST DASH ON LEFT + RIGHT SIDES.
- D-RING STRAP FROM TOWER GOES THROUGH + BEHIND BOLSTER PAD.

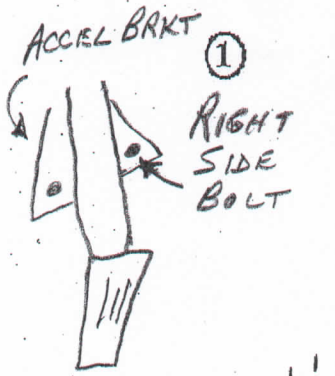

Retention Strap???

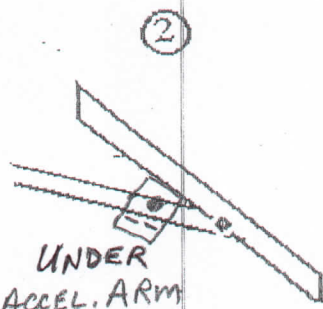

Throttle Block

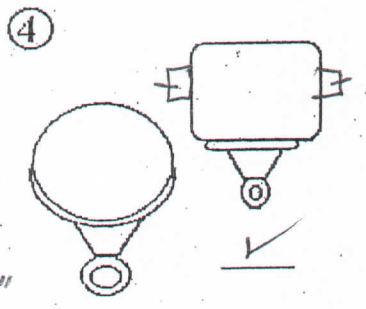
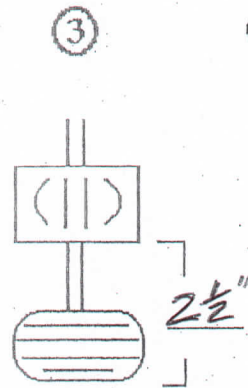

Draw in position of camlock

Enter measurements in blanks.

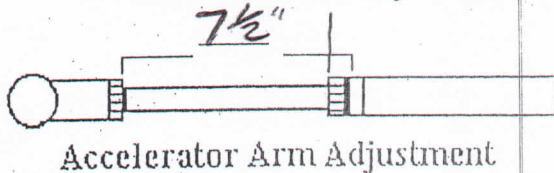
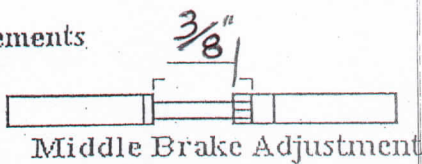

CUT THROTTLE BLOCK ROD END BEARING TURNED OUT $\frac{3}{8}$ "

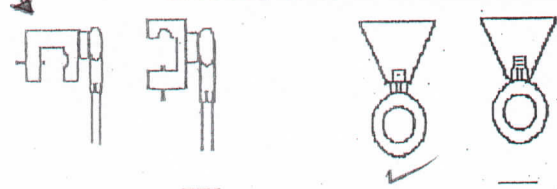
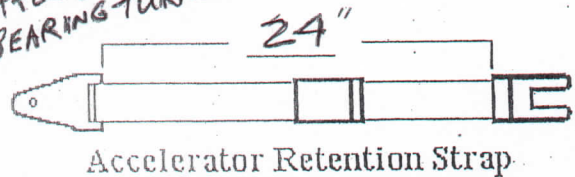

Automobility Vehicle Documentation Form AM-310-B
Vehicle Information Data:

Make GMC/CHEV. Model YUKON Year 2009
+ YUKON/DENALI/TAMO
+ SUBURBAN
 Hand Control Model # 22321

- Notes: — LEFT OFFSET LOWER BRAKE ARM
 — 28° UPPER ACCELERATOR ARM
 — TILT STEERING IN FULL UPRIGHT POSITION
 — CAMLOCK ON LEFT SIDE BEHIND SIGNAL LEVER AND BETWEEN GEAR SHIFT AND IGNITION SWITCH ON RIGHT SIDE
 — D-RING GOES THROUGH AND BEHIND BOLSTER PAD.

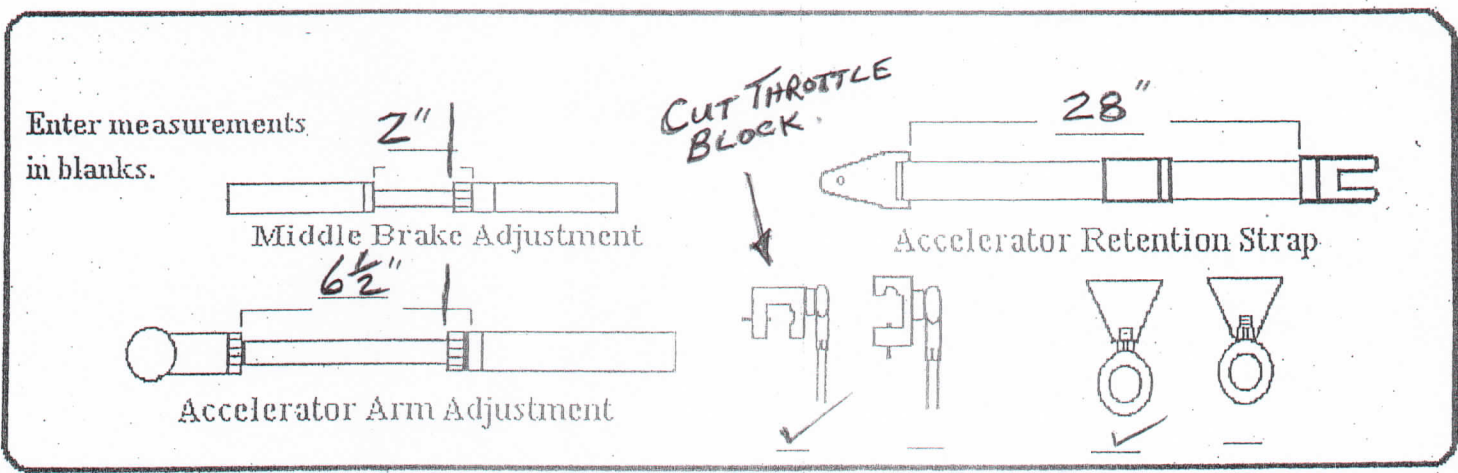
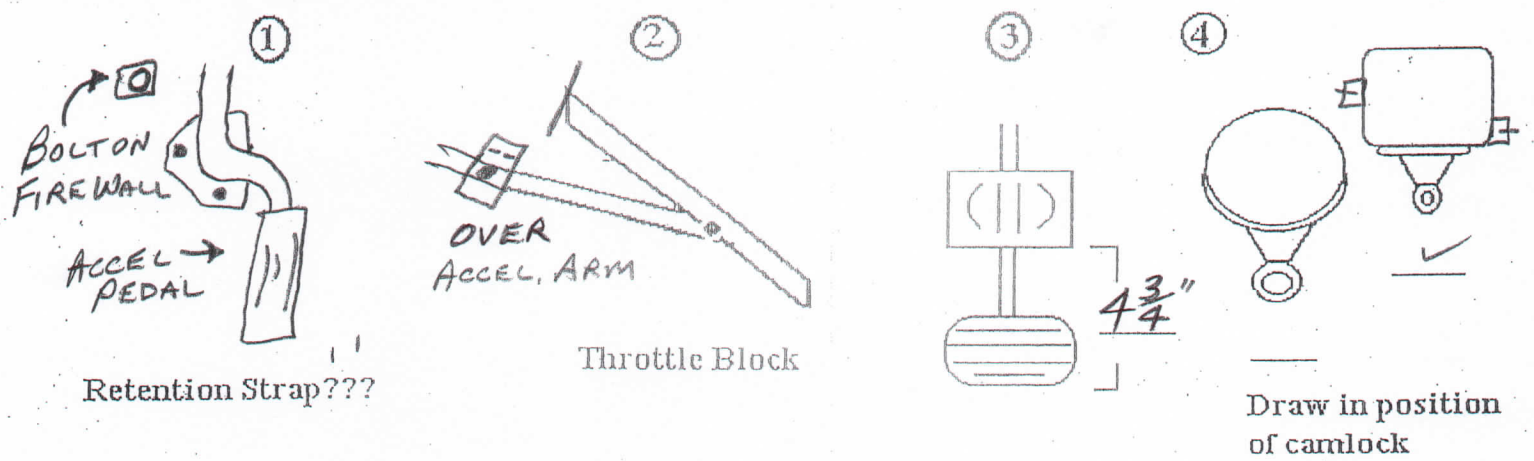

Automobility Vehicle Documentation Form AM-310-B
Vehicle Information Data:

Make BUICK Model ENCLAVE Year 2009

Hand Control Model # 21221

- Notes:
- TILT STEERING IN FULL UPRIGHT POSITION AND TELESCOPE OUT FROM DASH 1".
 - CAMLOCKS AGAINST DASH ON LEFT + RIGHT SIDES.
 - RIGHT OFFSET LOWER BRAKE ARM
 - REMOVE BRAKE BLOCK WEDGE PLATE + REPLACE STANDARD 2 1/2" BOLTS WITH MINIMUM 3" BOLTS

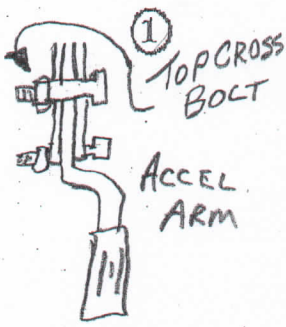

Retention Strap???

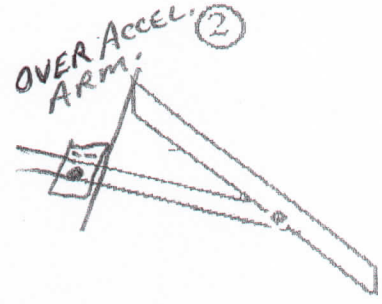

Throttle Block

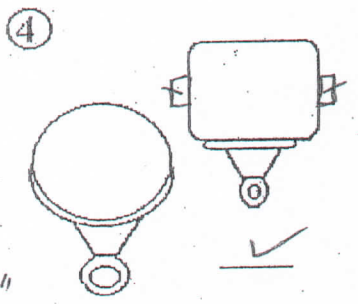
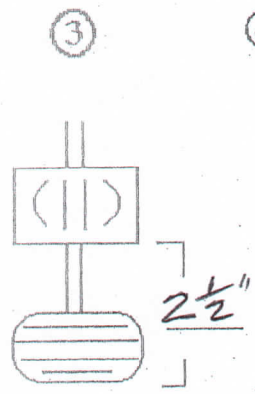

Draw in position of camlock

Enter measurements in blanks.

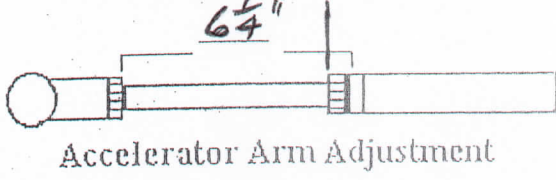
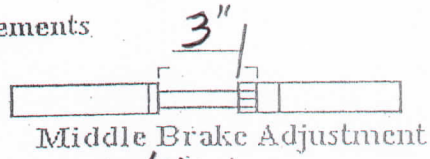

CUT THROTTLE BLOCK

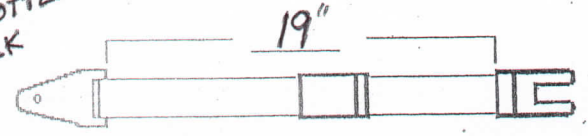

Accelerator Retention Strap

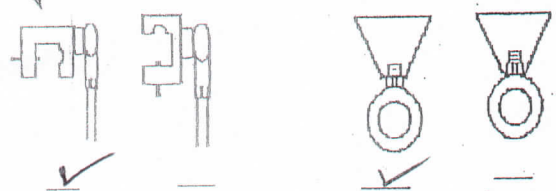

Automobility Vehicle Documentation Form AM-310-B
 Vehicle Information Data:

Make GMC/CHEV. Model CANYON/COLORADO Year 2009

Hand Control Model # 23221

- Notes: — STRAIGHT LOWER BRAKE ARM
 — TILT STEERING DOWN 3 POSITIONS TO TIGHTEN AND FLIP LOCKING TABS ON CAMLOCKS, CAMLOCKS POSITIONED ON TOP OF STEERING COLUMN.
 — TOWER STRAP ON LEFT SIDE IN FRONT OF TILT KNOB AND STRAP ON RIGHT SIDE GOES BEHIND GEAR SHIFT. ONCE TIGHT, TILT STEERING TO FULL UPRIGHT POSITION.
 — D-RING FROM TOWER GOES THROUGH + BEHIND BOLSTER PAD.

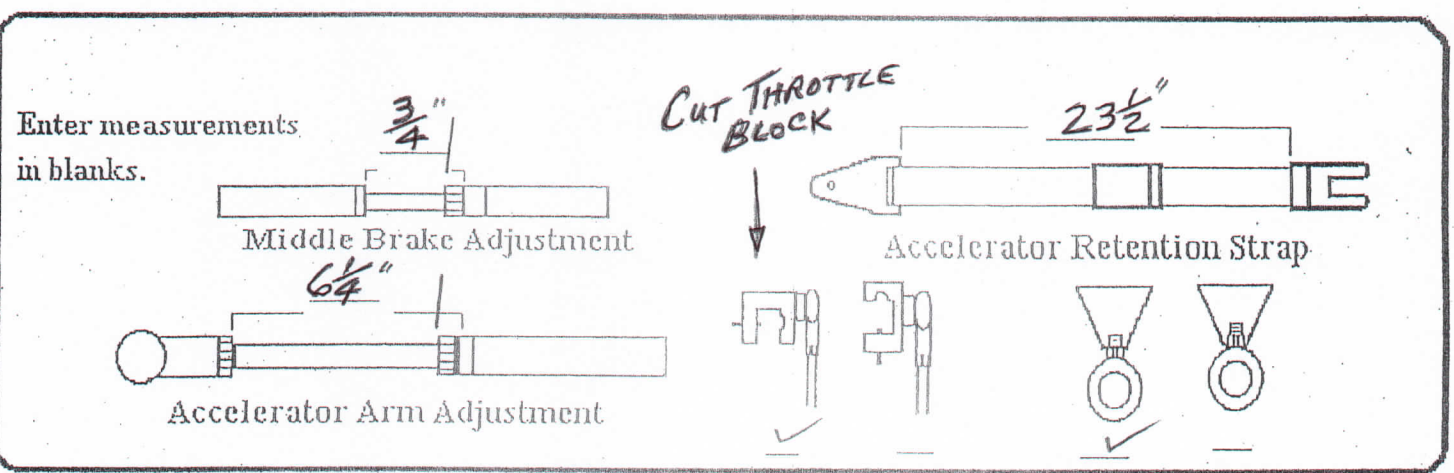
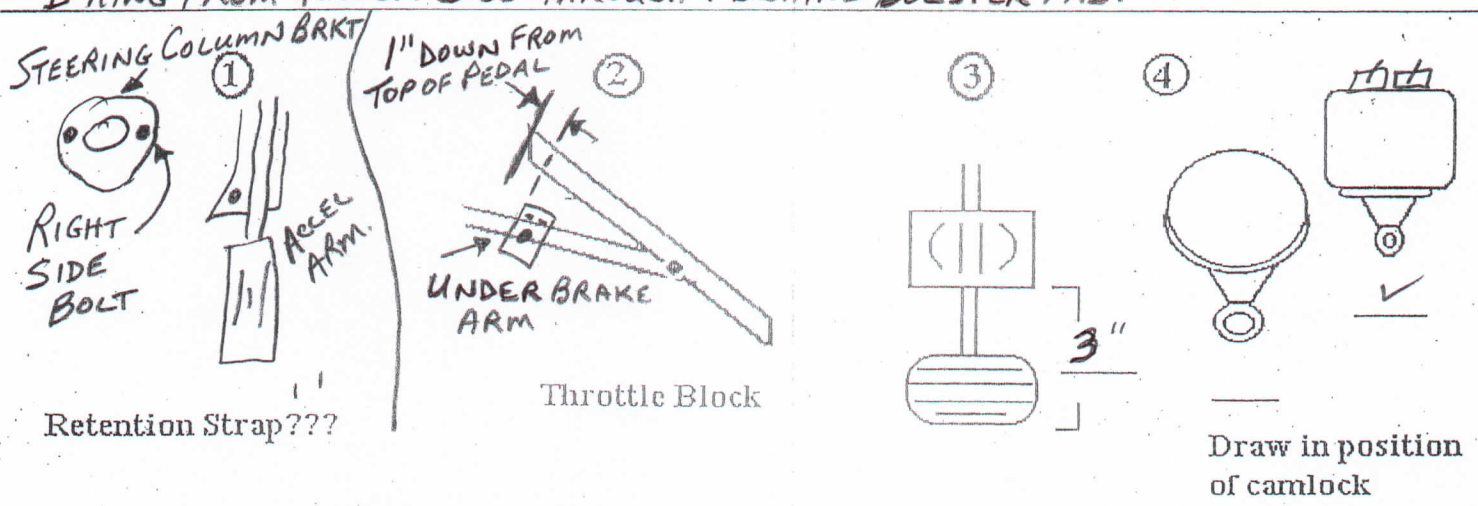

Automobility Vehicle Documentation Form AM-310-B
Vehicle Information Data:

Make BUICK Model ALLURE Year 2009

Hand Control Model # 21221

(HARD)
INSTALLATION

- Notes: - RIGHT OFFSET LOWER BRAKE ARM
 - TILT STEERING DOWN $\frac{1}{2}$ " FROM UPRIGHT POSITION.
 - CAMLOCKS GO BEHIND TILT KNOB ON LEFT SIDE AND BETWEEN GEAR SHIFT + DASH ON THE RIGHT SIDE.
 - STANDARD THROTTLE BLOCK OVER ACCEL ARM AND TO THE LEFT SIDE. THE ACCEL RUBBER/PLASTIC PEDAL MUST BE REMOVED, (CONSIDER HARD) AS THE ARM IS ALMOST TOUCHING THE TRANSMISSION HUMPH.

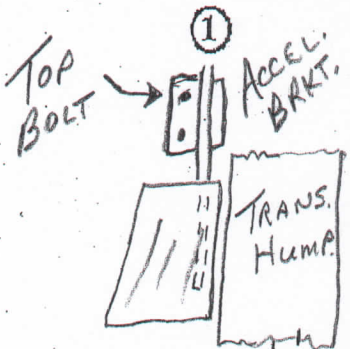

Retention Strap???

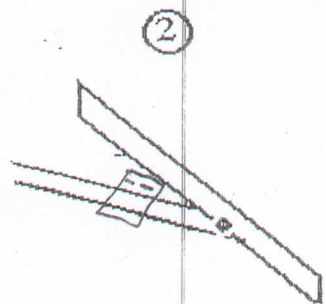

Throttle Block

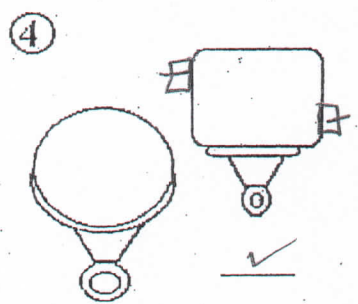
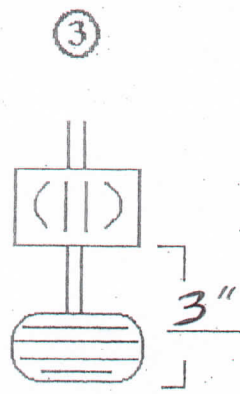

Draw in position of camlock

Enter measurements in blanks.

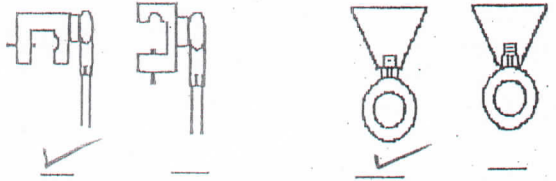
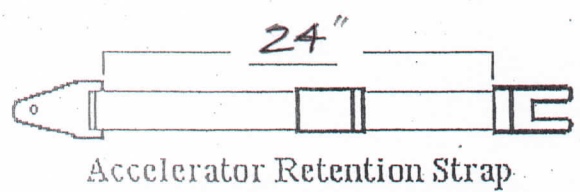
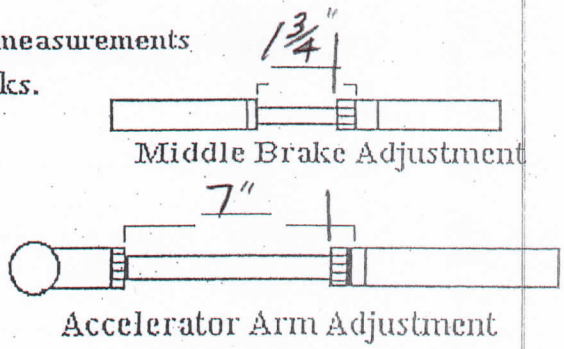

Automobility Vehicle Documentation Form AM-310-B
Vehicle Information Data:

Make BUICK Model LUCERNE Year 2009

Hand Control Model # 21221

Notes:

- TILT STEERING DOWN 1 NOTCH FROM UPRIGHT POSITION
- CAMLOCKS AGAINST DASH AT TOP OF STEERING COLUMN
- RIGHT OFFSET LOWER BRAKE ARM

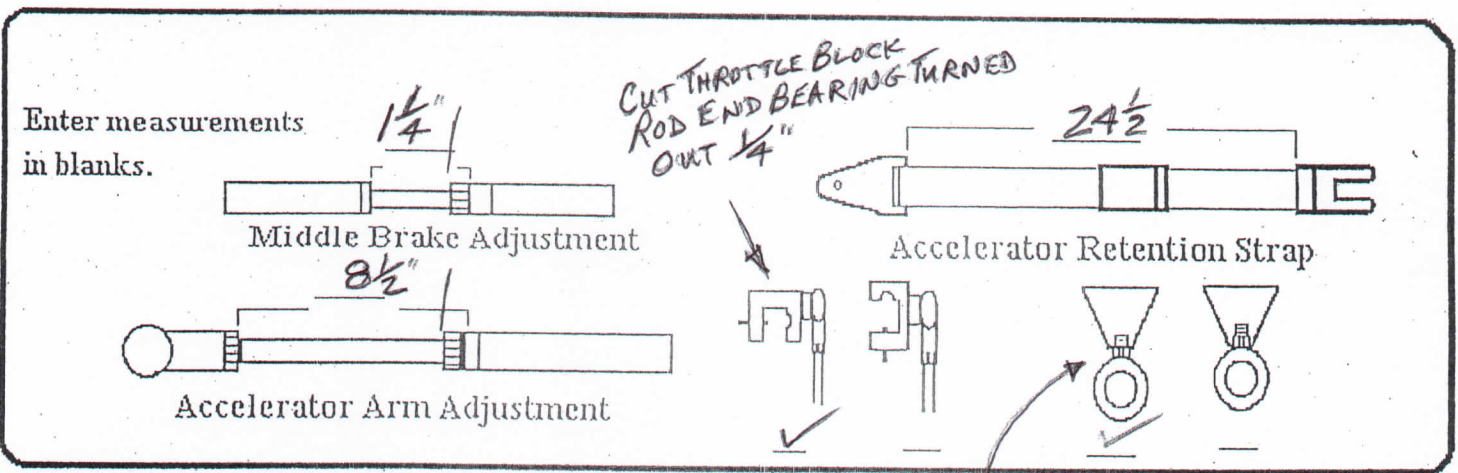
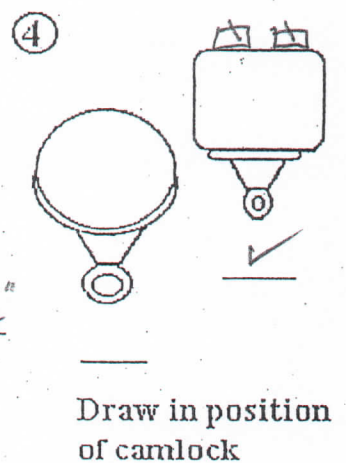
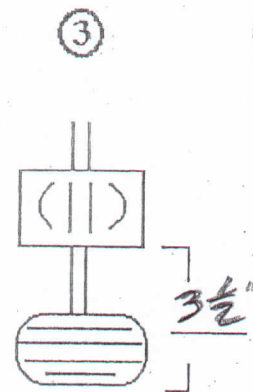
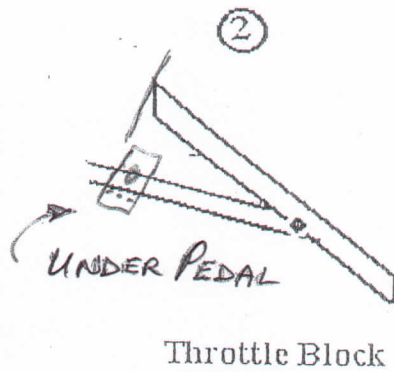
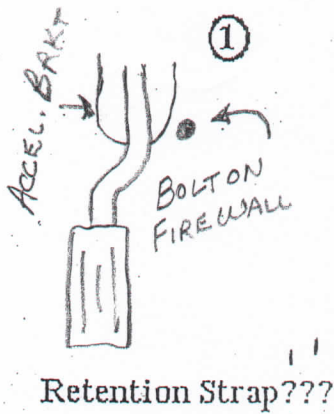

Automobility Vehicle Documentation Form AM-310-B
Vehicle Information Data:

Make GMC/CHEV. Model SIERRA 1500 Year 2009
↳ SILVERADO ✓

Hand Control Model # 23321

Notes:

- 28° UPPER ACCELERATOR ARM
- STRAIGHT LOWER BRAKE ARM
- TILT STEERING IN UPRIGHT POSITION
- D-RING STRAP FROM TOWER GOES THROUGH AND BEHIND THE BOLSTER PAD.
- TOWER STRAP BETWEEN DASH + TILT STEERING KNOB ON LEFT SIDE AND BETWEEN GEAR SHIFT + IGNITION ON RIGHT SIDE.

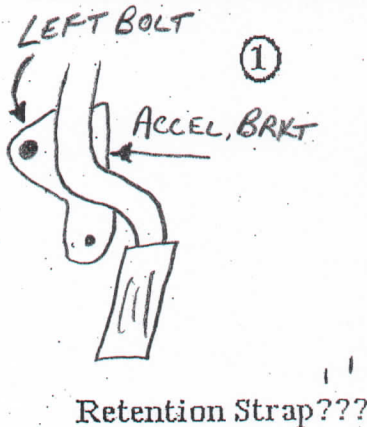

Retention Strap???

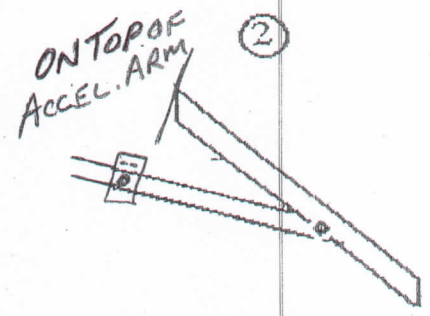

Throttle Block

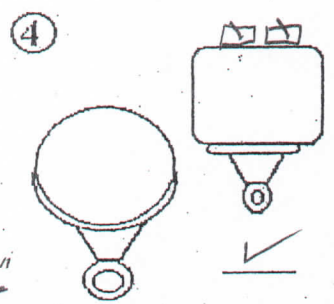
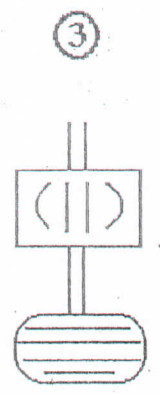

Draw in position of camlock

Enter measurements in blanks.

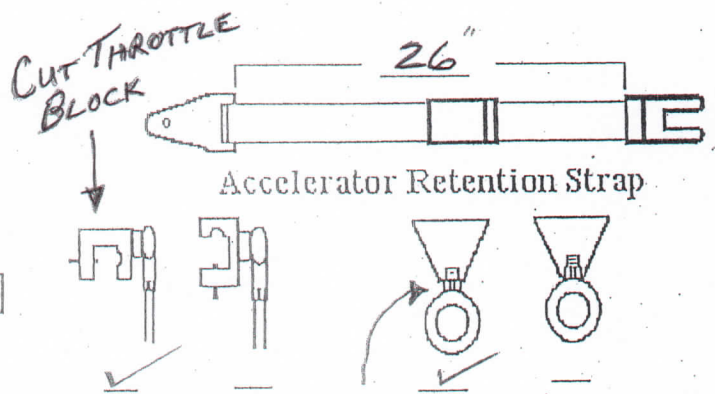
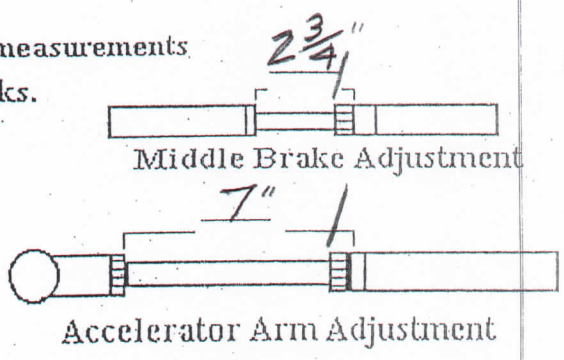

EYERING TURNED OUT 1/2"

Automobility Vehicle Documentation Form AM-310-B
Vehicle Information Data:

Make GMC/SATURN Model ACADIA/OUTLOOK Year 2009

Hand Control Model # 21221

(HARDER INSTALLATION)

Notes:

- TILT STEERING UP $\frac{1}{2}$ " FROM LOWEST POSITION AND TELESCOPE OUT FROM DASH $1\frac{1}{2}$ "
- CAMLOCKS AGAINST THE DASH ON LEFT + RIGHT SIDES
- RIGHT OFFSET LOWER BRAKE ARM
- REMOVE BRAKE BLOCK WEDGE PLATE + REPLACE STANDARD $2\frac{1}{2}$ " BOLTS WITH MINIMUM 3" BOLTS.

